

The Floor System The Others Look Up To



Steel Joist System

Product Manual

The Steel Joist System designed for fast, accurate assembly with a tab connection system and optional pre-punched service holes.

Table of Contents

Overview.....	3
Mechanical Properties.....	4
Design.....	4
Joist Selection.....	5
Live Load Span Tables.....	7
Cantilever Joists.....	8
Standard Connection Details.....	9
Fire and Acoustic Design.....	11
Vibration Design.....	20
Durability.....	20
Serviceable Life.....	21
Storage and Handling.....	21
Notes.....	22



19 June 2018

Overview

The SPEEDFLOOR® Steel Joist System is an engineered floor solution providing exceptional performance and construction efficiency. The joist has been engineered for strength and ease of installation while offering economical spanning performance that is adaptable to a variety of building designs and construction methods.



Practical, durable, simple

The system consists of cold formed, galvanised lipped c-section joists and perimeter channels incorporating a unique 'tab' connection with an option for pre-punched service holes in the web of the joist.

Application

The long spanning capability and construction flexibility, along with other features, allow ease of inclusion into a variety of building designs and construction methodologies.

The SPEEDFLOOR® Joist System is fully engineered and offers span tables that assist with council approvals.

Specifications for fire ratings and acoustic solutions for architects, engineers, and developers are also available.

Applications include mezzanine floors in commercial buildings, floors in portal framed sheds, platforms for industrial structures, residential mid floors, sub floors on piles and transportable units.

19 June 2018

Mechanical Properties

The SPEEDFLOOR® Steel Joist is manufactured from steel which has a minimum yield stress of 250MPa, a minimum tensile stress of 280MPa and a minimum galvanised coating thickness of 275g/sq m. The cold formed process enhances the yield stress and tensile strength of the rollformed shape and along with the flanged holes, produces an accurate, rigid section that has high load carrying characteristics.

SPEEDFLOOR® offer the SPEEDFLOOR® Steel Floor Joist System in a range of section sizes

"C"Section	Thickness (mm)	Second moment of area (full)		Section modulus (full)	Moment Capacity (distortional buckling)	Shear capacity (reduced for web penetrations)	End Connection Capacity
		1x (10 ⁶ mm ⁴)	1y (10 ⁶ mm ⁴)	Zx (10 ³ mm ³)	ΦM _{dbx} (kNm)	ΦV _v (kN)	kN
140x45	1.55	1.110	0.102	15.840	3.56	22.60	6.09
150x45	1.55	1.110	0.102	15.840	3.56	22.60	6.09
190x45	1.55	2.303	0.117	24.240	4.71	13.79	6.09
240x45	1.85	4.818	0.138	40.150	7.21	18.41	15.00
250x45	1.85	5.329	0.139	42.630	7.53	18.80	15.00
290x45	2.5	10.240	0.184	70.630	13.28	36.54	20.28

Notes

For 150 & 250 joist spans use the 140 & 240 tables provided. Joist spans over 3m are to have at least 1 row of full depth mid span blocking. For definition of distortional buckling, refer AS/NZS 4600:2005. End connection capacity based on bearing capacity of 10g tek screws as per AS/NZS 4600:2005. The section modulus Zx in the table is for the full section. The actual section modulus varies depending on design stress. This table should be used in conjunction with the design requirements of AS/NZS 4600:2005.

Design

Design principles: SPEEDFLOOR® Steel Joists have been designed to comply with NZS 3404, AS/NZS 4600:2005 and AS 4100. They also comply with sensitivity deflection and dynamic vibration requirements imposed by AS 3623 and NZS1170.0. Loading is based on NZS1170.1.

Design parameters: Service holes to be 300mm minimum away from any load bearing supports and at a minimum of 1000mm centres apart.

Material: SPEEDFLOOR® joists are rollformed from zinc coated steel coil conforming to AS 1397. The minimum mass coating of galvanizing is 275g/m². The standard steel used is Grade 250 and has a minimum yield stress of 250MPa and a minimum tensile stress of 280MPa.

The deadload of the span tables is calculated at 0.5kPa. For continuous spans the max span is to be reduced by 15%. Service holes are to be placed 300mm minimum away from any load bearing supports and at a minimum of 1000mm centres.

- A. FJ140 No Web Hole allowed
- B. FJ190 90mm diameter
- C. FJ240 140mm diameter
- D. FJ290 140mm diameter



19 June 2018

Joist Selection

Live load span tables – floor joist:

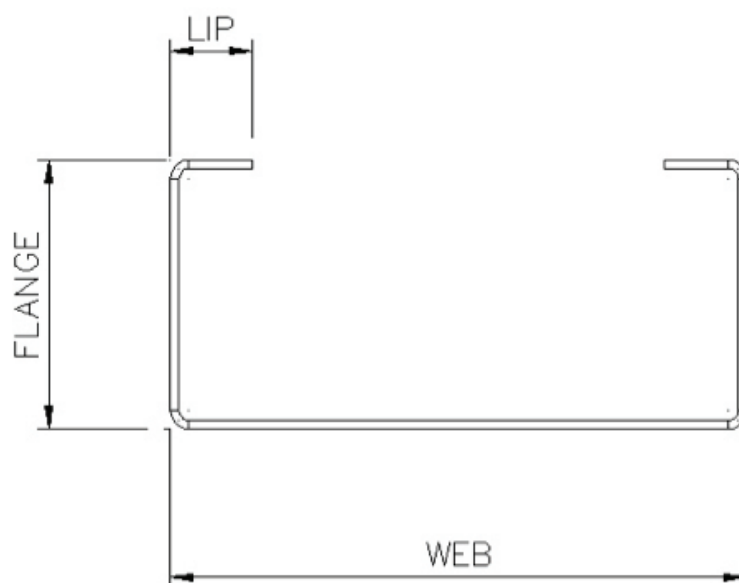

Max Span (m) of joists at nominated centres (mm) for 1.5kPa live load – Typical for Residential applications.

Profile	Web	Flange	Lip	Material	Max Span*		
					400 Centres	450 Centres	600 Centres
FJ140	140	45	15	1.55	3.7	3.4	3.1
FJ190	190	45	15	1.55	4.7	4.5	4.1
FJ240	240	45	15	1.85	5.7	5.5	5.1
FJ290	290	45	15	2.50	6.9	6.7	6.2

Max Span (m) of joists at nominated centres (mm) for 3.0kPa live load – Typical for Commercial applications.

FJ140	140	45	15	1.55	3.5	3.4	3.0
FJ190	190	45	15	1.55	4.3	4.0	3.5
FJ240	240	45	15	1.85	5.1	5.0	4.3
FJ290	290	45	15	2.50	6.2	6.0	5.6

Max Span (m) of joists at nominated centres (mm) for 5.0kPa floor live load - Typical for Industrial applications.

FJ140	140	45	15	1.55	2.9	2.7	2.4
FJ190	190	45	15	1.55	3.4	3.2	2.8
FJ240	240	45	15	1.85	4.2	4.0	3.4
FJ290	290	45	15	2.50	5.6	5.3	4.6

Max total deadload is 0.5kPa, the span tables are for single span, if joists are used in continuous span the max span should be reduced by 15%. The maximum length of a joist should be no longer than 6.9m. Service holes should be a minimum of 300mm minimum away from any load bearing supports and at a minimum of 1000mm centres apart. Joist spans of over 3.0m are to have at least one row of full depth mid-span blocking installed. Point loads on any joist are to be specifically engineered based on capacity tables.

19 June 2018

Joist Selection

Live load span tables – Perimeter Channel

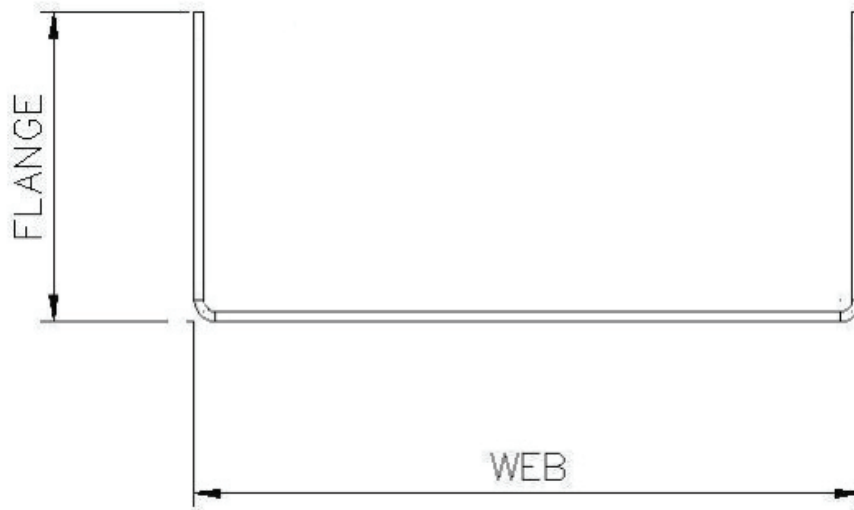

Max Span (m) of joists at nominated centres (mm) for 1.5kPa live load – Typical for Residential applications.

Joist Span up to:	Size	Max Perimeter Channel Span		
		1.5kPa	3kPa	5kPa
3000*	FJ140x1.55	1800	1300	1100
	FJ190x1.55	2100	1600	1200
	FJ240x1.85	2700	2000	1600
	FJ290x2.5	3700	2700	2200
4000*	FJ140x1.55	1600	1100	–
	FJ190x1.55	1800	1400	1100
	FJ240x1.85	2300	1700	1400
	FJ290x2.5	3200	2400	1900
5000*	FJ140x1.55	1400	1000	–
	FJ190x1.55	1600	1200	1000
	FJ240x1.85	2100	1600	1200
	FJ290x2.5	2800	2100	1700
6000*	FJ140x1.55	1300	–	–
	FJ190x1.55	1500	1100	–
	FJ240x1.85	1900	1400	1100
	FJ290x2.5	2600	1900	1500

*Perimeter Channel spans are not applicable for support of a loadbearing wall or roof loads.

*Balustrade connecting to the channel need to be independently assessed for suitability.

*No service holes are allowed within the span.

Live Load Span Tables

- Composite C section perimeter channels.

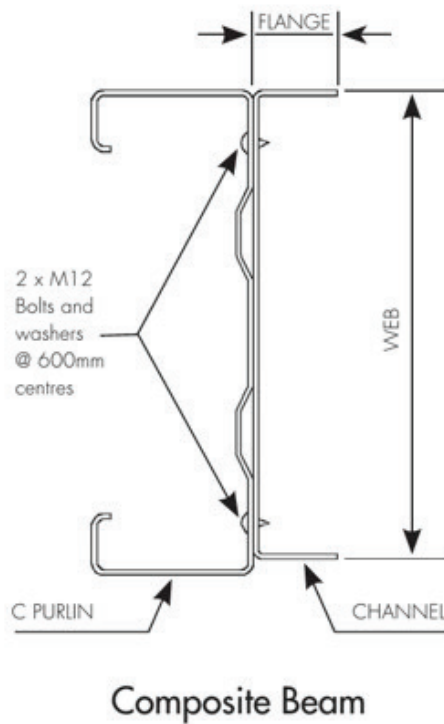

Joist Span up to:	Composite Section Size	1.5kPa	3kPa	5kPa
3000*	PC140 + C200/18	4.2	3.6	2.8
	PC190 + C200/18	4.3	3.6	2.9
	PC240 + C250/18	5.1	4.4	3.6
	PC290 + C300/18	6.0	5.2	4.1
4000*	PC140 + C200/18	3.9	3.1	2.5
	PC190 + C200/18	4.0	3.1	2.5
	PC240 + C250/18	4.7	3.9	3.1
	PC290 + C300/18	5.6	4.5	3.6
5000*	PC140 + C200/18	3.7	2.8	2.2
	PC190 + C200/18	3.8	2.8	2.2
	PC240 + C250/18	4.5	3.5	2.8
	PC290 + C300/18	5.3	4.0	3.2
6000*	PC140 + C200/18	3.4	2.5	2.0
	PC190 + C200/18	3.4	2.5	2.0
	PC240 + C250/18	4.2	3.2	2.5
	PC290 + C300/18	4.9	3.7	2.9

* Tables relate to single span floors. Perimeter Channels to be fixed every 600mm with 2 x M12 bolts and washers to C Purlin.

Cantilever Joists

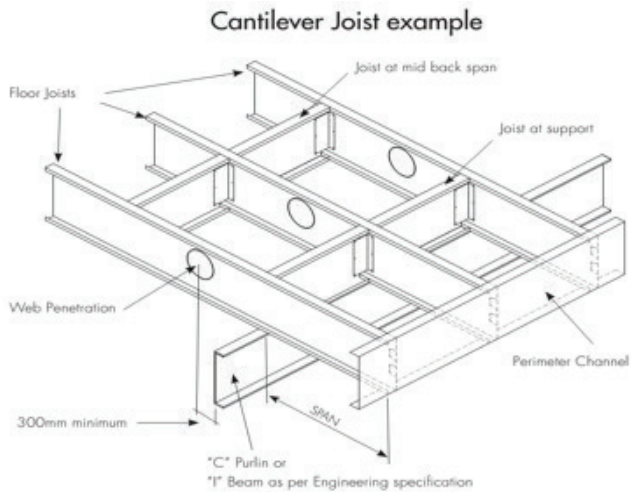

Profile	Web	Flange	Lip	Material	Max Span*		
					400 Centres	450 Centres	600 Centres
FJ140x1.55	140	45	15	1.55	0.9	0.9	0.8
FJ190x1.55	190	45	15	1.55	1.2	1.1	1.0
FJ240x1.85	240	45	15	1.85	1.5	1.5	1.3
FJ290x2.5	290	45	15	2.50	2.0	1.9	1.7

NOTE: Minimum Back Span required is 2 x Cantilever Span. Maximum live load of 5kPa. Dynamic vibration of cantilevers is based on NZS1170.0:2002 with a 1-2mm deflection under a 1kN point load and assumes a rigid wall below. For cantilever joists supported by beams, specific vibration design should be undertaken. No service penetrations on cantilever span.



19 June 2018

Standard Connection Details

Steel Joist to Concrete Wall



Steel Joist to PFC Beam

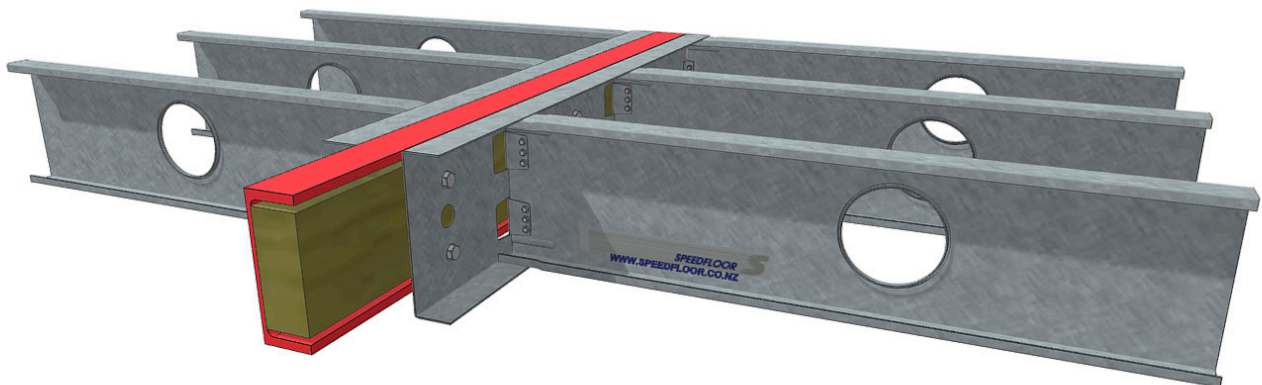

19 June 2018

Steel Joist on Top of Concrete Wall

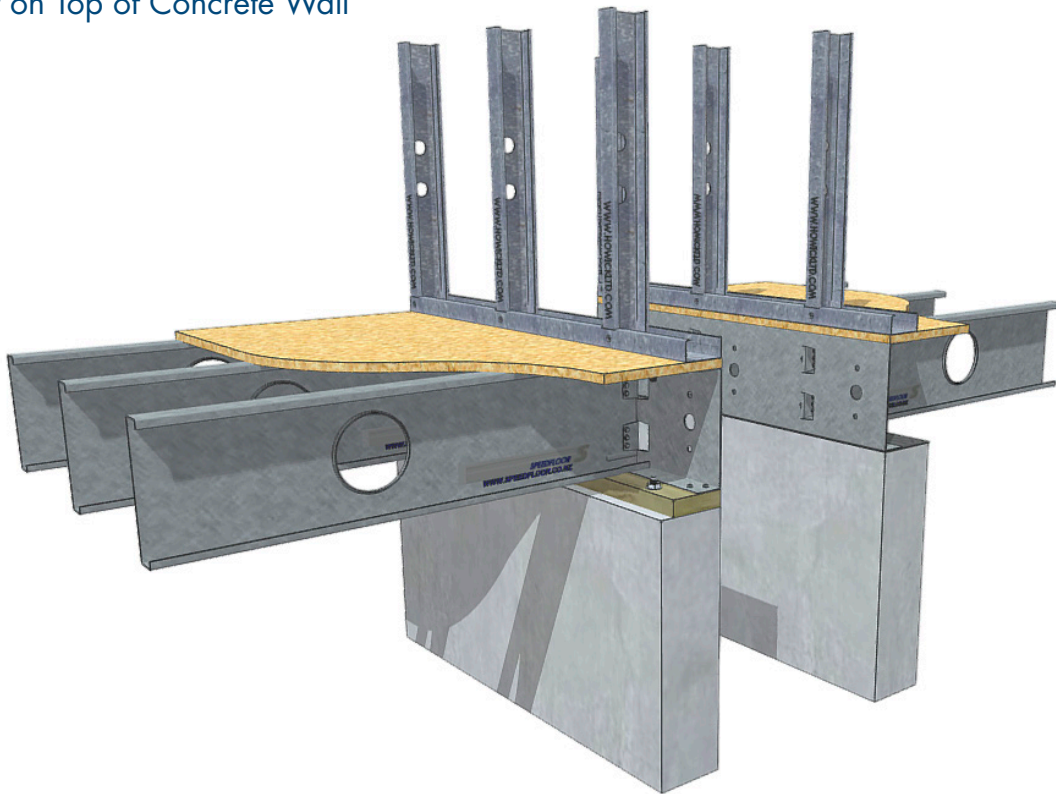

Steel Joist Ext Wall Bracket Detail

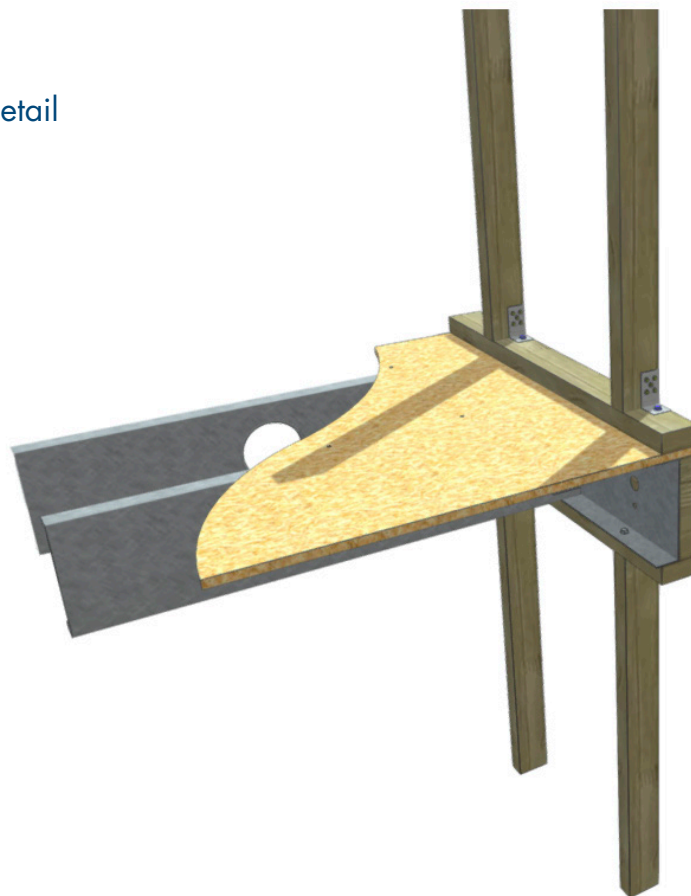

19 June 2018

Fire and Acoustic Design

A number of fire rated and acoustic solutions are available for the SPEEDFLOOR® Steel Joist system. If the included designs do not meet the required specifications please contact the SPEEDFLOOR® area representative.



FIRE RATED FLOOR/CEILING SYSTEMS

Steel joist

Specification number	Performance	Specifications
GBSJ 30	FRR 30/30/30	Lining 1 layer 13mm GIB Fyreline® LB/NLB Load bearing
	STC 34	
	Rw 34	
	IIC 30	

FLOOR FRAMING

The steel floor structure shall be specifically designed and have minimum 190mm-deep C-section joists with 45mm flanges and a thickness of 1.55mm, spaced at no more than 600mm centres.

Framing is required at the perimeter of the ceiling lining and at longitudinal sheet joints. Suitable perimeter framing includes a minimum 35mm x 35mm x 0.55mm steel perimeter angle or steel nogs.

Longitudinal sheet joints are supported on 0.55mm-thick C-section steel nogs connected to the joists. The nogs have a minimum width of 50mm with 25mm vertical legs.

FLOORING

Minimum flooring shall be nominal 20mm oriented strand board or particle board, or minimum 17mm-thick structural plywood fixed to the joists in accordance with the manufacturers' specifications.

Flooring sheet joints must have a polypropylene tongue and groove jointer or be formed over framing.

CEILING LINING

1 layer of 13mm GIB Fyreline® fixed at right angles to the underside of the floor joists.

All sheet joints must occur on joists or nogs.

Sheets shall be touch fitted.

FASTENING THE LINING

Fasteners

32mm x 8g GIB® Grabber® Drill Point Fine Thread Screws.

Fastener centres

Place fasteners at 150mm centres around the perimeter of each sheet and at 200mm centres along each joist.

Place fasteners 12mm from longitudinal sheet edges and 18mm from sheet ends.

WALL/CEILING JUNCTIONS

The internal angle between the ceiling and walls must be protected by GIB-Cove® adhered with GIB-Cove® Bond, or boxed corners (square stopped) filled and taped in accordance with the publication entitled "GIB® Site Guide".

JOINTING

All fastener heads stopped and all sheet joints tape reinforced and stopped in accordance with the publication entitled "GIB® Site Guide".

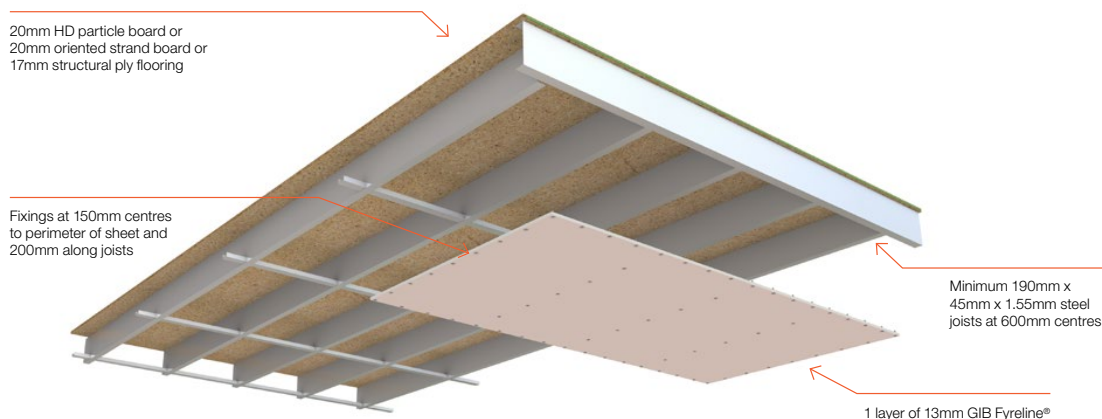

19 June 2018

Steel joist

Specification number	Performance	Specifications
GBSJ 60	FRR 60/60/60 STC 39 Rw 39 IIC 32	Lining 1 layer 16mm GIB Fyreline® LB/NLB Load bearing

FLOOR FRAMING

The steel floor structure shall be specifically designed and have minimum 190mm-deep C-section joists with 45mm flanges and a thickness of 1.55mm, spaced at no more than 600mm centres.

Framing is required at the perimeter of the ceiling lining and at longitudinal sheet joints. Suitable perimeter framing includes a minimum 35mm x 35mm x 0.55mm steel perimeter angle or steel nogs.

Longitudinal sheet joints are supported on 0.55mm-thick C-section steel nogs connected to the joists. The nogs have a minimum width of 50mm with 25mm vertical legs.

FLOORING

Minimum flooring shall be nominal 20mm oriented strand board or particle board, or minimum 17mm-thick structural plywood fixed to the joists in accordance with the manufacturers' specifications.

Flooring sheet joints must have a polypropylene tongue and groove jointer or be formed over framing.

Flooring sheet joints without a jointer must have a bead of GIB Fire Soundseal® applied before sheets are locked together. Where tongue and groove jointers or sealant are not used, the fire rating will reduce to 60/60/45.

CEILING LINING

1 layer of 16mm GIB Fyreline® fixed at right angles to the underside of the floor joists.

All sheet joints must occur on joists or nogs.

Sheets shall be touch fitted.

FASTENING THE LINING

Fasteners

32mm x 8g GIB® Grabber® Drill Point Fine Thread Screws.

Fastener centres

Place fasteners at 150mm centres around the perimeter of each sheet and at 200mm centres along each joist.

Place fasteners 12mm from longitudinal sheet edges and 18mm from sheet ends.

WALL/CEILING JUNCTIONS

The internal angle between the ceiling and walls must be protected by GIB-Cove® adhered with GIB-Cove® Bond, or boxed corners (square stopped) filled and taped in accordance with the publication entitled "GIB® Site Guide".

JOINTING

All fastener heads stopped and all sheet joints tape reinforced and stopped in accordance with the publication entitled "GIB® Site Guide".

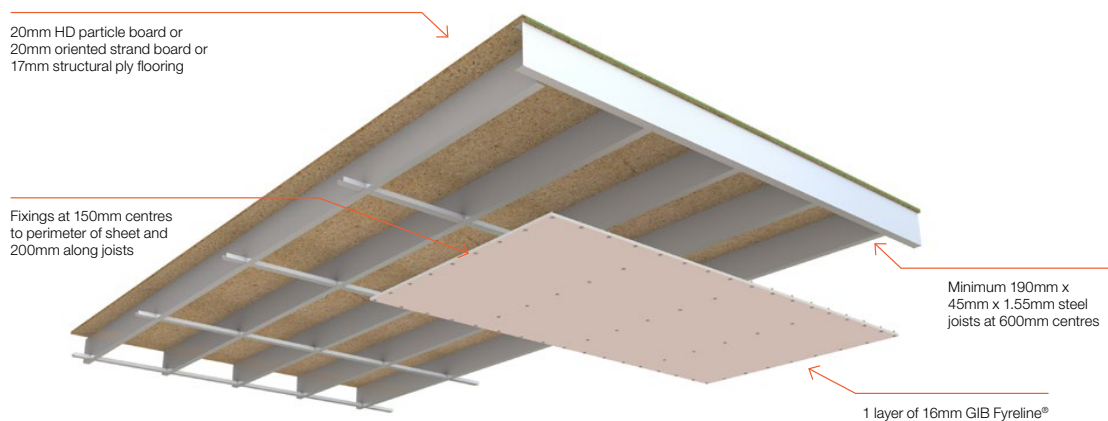

Universal ceiling systems

Specification number	Performance	Specifications
GBUC 30	FRR 30/30/30	Lining 1 layer 16mm GIB Fyreline® LB/NLB Load bearing

FRAMING

Timber or steel roof or floor/ceiling framing designed to meet structural criteria for strength and serviceability under dead and live loads.

The separation distance between the ceiling linings and any flooring or roofing material shall be 90mm minimum.

Linings shall be supported by framing members with a minimum width of 35mm spaced at 600mm centres maximum.

Solid nogs shall be provided at 1200mm centres maximum and to the perimeter of the fire rated ceiling.

If timber-framed construction applies, the nogs shall be 70mm x 35mm minimum.

CEILING LINING

1 layer of 16mm GIB Fyreline® shall be fixed at right angles to the underside of the framing members.

All sheet joints must occur over solid framing.

Sheets shall be touch fitted.

Alternatively, longitudinal sheet edges may be back-blocked using a 300mm-wide strip of 16mm GIB Fyreline® adhered with GIB-Cove® Bond in accordance with the procedure outlined in the current "GIB® Site Guide".

FASTENING THE LINING

Fasteners

Timber frame	Steel frame
41mm x 6g GIB® Grabber® High Thread Drywall Screws	32mm x 6g GIB® Grabber® Self Tapping Drywall Screws

Fastener centres

Place fasteners 12mm from longitudinal sheet edges and 18mm from sheet ends. This distance may be reduced to 12mm from sheet ends at butt joints on furring channels.

Place fasteners at 200mm centres around the sheet perimeters, along each intermediate framing member and where sheet end butt joints occur.

WALL/CEILING JUNCTIONS

The internal angle between the ceiling and walls must be protected by GIB-Cove® adhered with GIB-Cove® Bond, or boxed corners (square stopped) filled and taped in accordance with the publication entitled "GIB® Site Guide".

JOINTING

All fastener heads stopped and all sheet joints tape reinforced and stopped in accordance with the publication entitled "GIB® Site Guide".

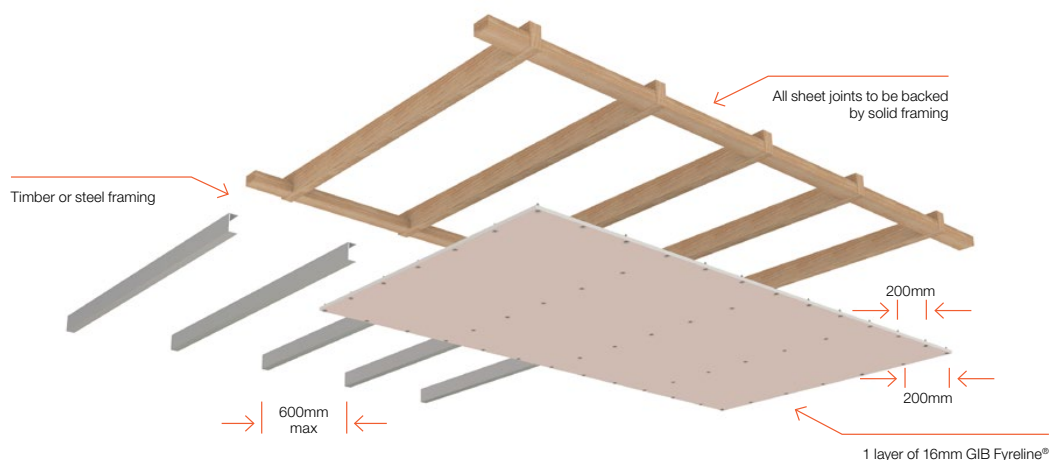

Universal ceiling systems

Specification number	Performance	Specifications
GBUC 60	FRR 60/60/60	Lining 2 layers 13mm GIB Fyreline® LB/NLB Load bearing

FRAMING

Timber or steel roof or floor/ceiling framing designed to meet structural criteria for strength and serviceability under dead and live loads.

The separation distance between the ceiling linings and any flooring or roofing material shall be 90mm minimum.

Linings shall be supported by framing members with a minimum width of 35mm spaced at 600mm centres maximum.

In respect of the FRR for this particular system, nogs are required only at the perimeter of the fire rated ceiling.

If timber-framed construction applies, the nogs shall be 70mm x 35mm minimum.

CEILING LINING

2 layers of 13mm GIB Fyreline® shall be fixed at right angles to the underside of the framing members.

The joints of the second layer are offset 600mm from those in the first layer.

All sheet end butt joints must occur over solid framing.

Sheets shall be touch fitted.

FASTENING THE LINING

Fasteners

Layer	Timber frame	Steel frame
Inner layer	41mm x 6g GIB® Grabber® High Thread Drywall Screws	25mm x 6g GIB® Grabber® Self Tapping Drywall Screws
Outer layer	51mm x 7g GIB® Grabber® High Thread Drywall Screws	41mm x 6g GIB® Grabber® Self Tapping Drywall Screws

Fastener centres (both layers)

Place fasteners 12mm from longitudinal sheet edges and 18mm from sheet ends. This distance may be reduced to 12mm from sheet ends at butt joints on furring channels.

Place fasteners at 200mm centres around the ceiling perimeter, along each intermediate framing member and where sheet end butt joints occur.

WALL/CEILING JUNCTIONS

The internal angle between the ceiling and walls must be protected by GIB-Cove® adhered with GIB-Cove® Bond, or boxed corners (square stopped) filled and taped in accordance with the publication entitled "GIB® Site Guide".

JOINTING

Inner layer: Unstopped.

Outer layer: All fastener heads stopped and all sheet joints tape reinforced and stopped in accordance with the publication entitled "GIB® Site Guide".

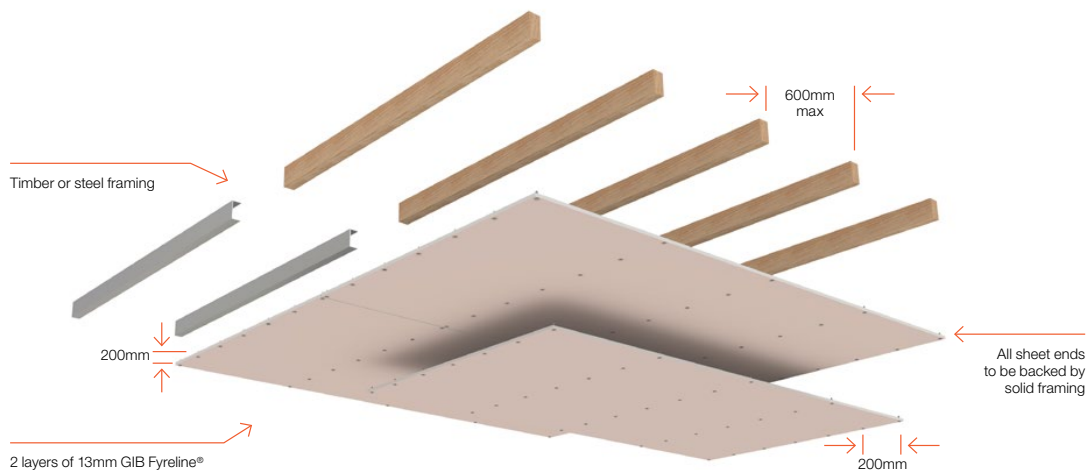

Universal ceiling systems

Specification number	Performance	Specifications
GBUC 90	FRR 90/90/90	Lining 2 layers 19mm GIB Fyreline® LB/NLB Load bearing
GBUC 120*	FRR 120/120/120	Lining 2 layers 19mm GIB Fyreline® LB/NLB Load bearing

FRAMING

Timber or steel roof or floor/ceiling framing designed to meet structural criteria for strength and serviceability under dead and live loads.

The separation distance between the ceiling linings and any flooring or roofing material shall be 90mm minimum.

Linings shall be supported by framing members with a minimum width of 35mm spaced at 600mm centres maximum.

Nogs are required only at the perimeter of the fire rated ceiling.

If timber-framed construction applies, the nogs shall be 70mm x 35mm minimum.

CEILING LINING

2 layers of 19mm GIB Fyreline® shall be fixed at right angles to the underside of the framing members.

The joints of the second layer are offset 600mm from those in the first layer.

All sheet end butt joints must occur over solid framing.

Sheets shall be touch fitted.

**Note: A 120-minute FRR (GBUC 120) is achieved with a minimum 200mm separation distance between the ceiling linings and any flooring or roofing material, or with the addition of Pink® Batts® BIB R1.8 (75mm) glass wool insulation installed between the framing.*

FASTENING THE LINING

Fasteners

Layer	Timber frame	Steel frame
Inner layer	41mm x 6g GIB® Grabber® High Thread Drywall Screws	32mm x 6g GIB® Grabber® Self Tapping Drywall Screws
Outer layer	57mm x 7g GIB® Grabber® High Thread Drywall Screws	51mm x 7g GIB® Grabber® Self Tapping Drywall Screws

Fastener centres (both layers)

Place fasteners 12mm from longitudinal sheet edges and 18mm from sheet ends. This distance may be reduced to 12mm from sheet ends at butt joints on furring channels.

Place fasteners at 200mm centres around the ceiling perimeter, along each intermediate framing member and where sheet end butt joints occur.

WALL/CEILING JUNCTIONS

The internal angle between the ceiling and walls must be protected by GIB-Cove® adhered with GIB-Cove® Bond, or boxed corners (square stopped) filled and taped in accordance with the publication entitled "GIB® Site Guide".

JOINTING

Inner layer: Unstopped.

Outer layer: All fastener heads stopped and all sheet joints tape reinforced and stopped in accordance with the publication entitled "GIB® Site Guide".

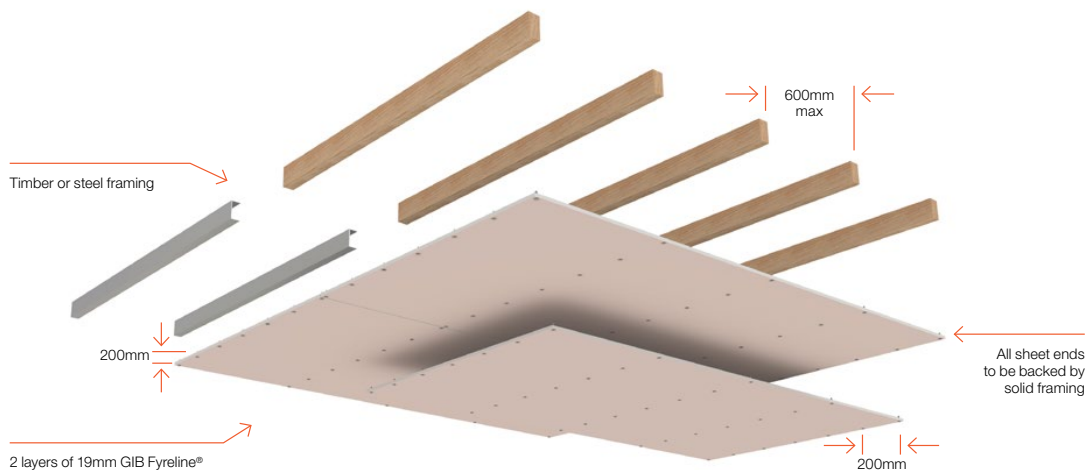

Floor/ceiling — steel joists

Specification number	Performance	Specifications
GBSJA 45	STC 55 Rw 55 FRR 45/45/45	Lining 2 x 13mm GIB Fyreline® LB/NLB Load bearing IIC* 48–72

FLOOR FRAMING

Steel floor joists shall be a minimum 190mm deep C-section with 45mm flanges and a thickness of 1.55mm, spaced at no more than 600mm centres.

FLOORING

Flooring shall be nominal 20mm particle board or 20mm oriented strand board or minimum 17mm thick structural plywood fixed to the joists in accordance with the manufacturer's specifications. Flooring sheet joints must have a tongue and groove jointer, or be formed over framing.

If 17mm thick structural plywood is selected as the flooring material, one of the following floor coverings must be installed to achieve the listed STC and Rw performance:

- 4mm cushion-back vinyl; or,
- Wooden strip flooring; or,
- Ceramic tile; or,
- 40oz cut pile carpet loose laid on 8mm foam underlay.

GIB QUIET CLIP® AND BATTENS

The GIB Quiet Clip® is fastened to the joists at a maximum of 1200mm centres and minimum 900mm centres to support the GIB® Rondo® metal ceiling battens. Fasten each clip to the joist with 3 x 30mm x 10g Drill-Point Wafer Head Screws. The battens are spaced at a maximum of 600mm. A perimeter channel or GIBFix® Angle is required around the perimeter of the ceiling.

CEILING LINING

2 layers of 13mm GIB Fyreline® fixed at right angles to the battens. Offset the joints of the outer layer by 600mm from those of the inner layer. All sheet end butt joints shall occur on battens and are offset between first and second layers. Sheet joints are touch fitted.

SOUND CONTROL INFILL

Pink® Batts® BIB R1.8 (75mm) glass wool insulation installed between the joists.

FASTENING THE LINING

Fasteners

Inner layer: 32mm x 6g GIB® Grabber® Self Tapping Drywall Screws.

Outer layer: 41mm x 6g GIB® Grabber® Self Tapping Drywall Screws.

Fastener centres (both layers)

200mm centres along each batten and 100mm centres at butt end joints. Place fasteners 12mm from sheet edges.

WALL/CEILING JUNCTIONS

The internal angle between the ceiling and walls must be protected by GIB-Cove® adhered with GIB-Cove® Bond, or boxed corners (square stopped) filled and taped in accordance with the publication entitled GIB® Site Guide.

ACOUSTIC SEALANT

A bead of GIB Soundseal® acoustic sealant is required on the inner lining around the ceiling perimeter. The outer lining is then bedded onto the bead.

JOINTING

All fastener heads stopped and all sheet joints tape reinforced and stopped in accordance with the publication entitled GIB® Site Guide.

*Impact Insulation Class (IIC)

A performance of IIC 48 is achieved by a bare floor.

A performance of IIC 51 is achieved with a floor covering of 4mm cushion-backed vinyl.

A performance of IIC 72 is achieved with a floor covering of 40oz cut pile carpet loose laid on 8mm foam underlay.

Note: See page 90 for perimeter details.

Floor/ceiling — steel joists

Specification number	Performance	Specifications
GBSJA 45	STC 55 Rw 55 FRR 45/45/45	Lining 2 x 13mm GIB Fyreline® LB/NLB Load bearing IIC* 48-72

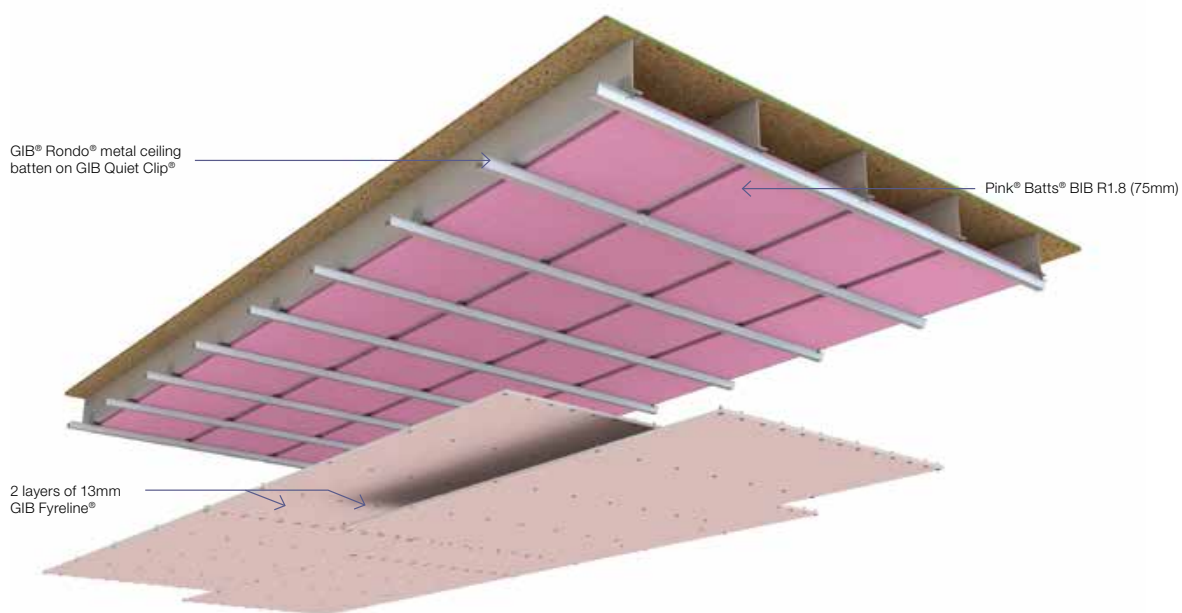

Floor/ceiling — steel joists

Specification number	Performance	Specifications
GBSJA 60	STC 56 Rw 55 FRR 60/60/60	Lining 1 x 16mm and 1 x 13mm GIB Fyreline® LB/NLB Load bearing IIC* 49–73

FLOOR FRAMING

Steel floor joists shall be a minimum 190mm deep C-section with 45mm flanges and a thickness of 1.55mm, spaced at no more than 600mm centres.

FLOORING

Flooring shall be nominal 20mm particle board or 20mm oriented strand board or minimum 17mm thick structural plywood fixed to the joists in accordance with the manufacturer's specifications. Flooring sheet joints must have a tongue and groove jointer, or be formed over framing.

If 17mm thick structural plywood is selected as the flooring material, one of the following floor coverings must be installed to achieve the listed STC and Rw performance:

- 4mm cushion-back vinyl; or,
- Wooden strip flooring; or,
- Ceramic tile; or,
- 40oz cut pile carpet loose laid on 8mm foam underlay.

GIB QUIET CLIP® AND BATTENS

The GIB Quiet Clip® is fastened to the joists at a maximum of 1200mm centres and minimum 900mm centres to support the GIB® Rondo® metal ceiling battens. Fasten each clip to the joist with 3 x 30mm x 10g Drill-Point Wafer Head Screws. The battens are spaced at a maximum of 600mm. A perimeter channel or GIBFix® Angle is required around the perimeter of the ceiling.

CEILING LINING

1 layer 16mm (inner) and 1 layer 13mm GIB Fyreline® (outer) fixed at right angles to the battens.

Offset the joints of the outer layer by 600mm from those of the inner layer. All sheet end butt joints shall occur on battens and are offset between first and second layers. Sheet joints are touch fitted.

SOUND CONTROL INFILL

Pink® Batts® BIB R1.8 (75mm) glass wool insulation installed between the joists.

FASTENING THE LINING

Fasteners

Inner layer: 32mm x 6g GIB® Grabber® Self Tapping Drywall Screws.

Outer layer: 41mm x 6g GIB® Grabber® Self Tapping Drywall Screws.

Fastener centres (both layers)

200mm centres along each batten and 100mm centres at butt end joints. Place fasteners 12mm from sheet edges.

ACOUSTIC SEALANT

A bead of GIB Soundseal® acoustic sealant is required on the inner lining around the ceiling perimeter. The outer lining is then bedded onto the bead.

WALL/CEILING JUNCTIONS

The internal angle between the ceiling and walls must be protected by GIB-Cove® adhered with GIB-Cove® Bond, or boxed corners (square stopped) filled and taped in accordance with the publication entitled GIB® Site Guide.

JOINTING

Inner layer: Unstopped.

Outer layer: All fastener heads stopped and all sheet joints tape reinforced and stopped in accordance with the publication entitled GIB® Site Guide.

*Impact Insulation Class (IIC)

A performance of IIC 49 is achieved by a bare floor.

A performance of IIC 52 is achieved with a floor covering of 4mm cushion-backed vinyl.

A performance of IIC 73 is achieved with a floor covering of 40oz cut pile carpet loose laid on 8mm foam underlay.

Note: See page 90 for perimeter details.

Floor/ceiling — steel joists

Specification number	Performance	Specifications
GBSJA 60	STC 56 Rw 55 FRR 60/60/60	Lining 1 x 16mm and 1 x 13mm GIB Fyreline® LB/NLB Load bearing IIC* 49–73

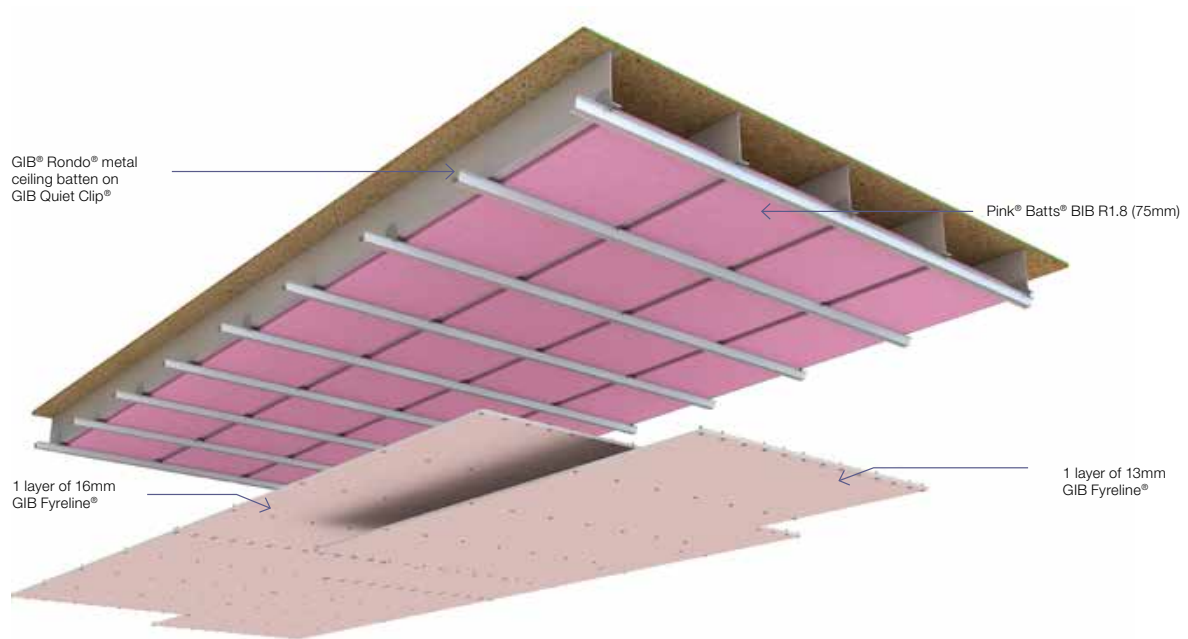

Vibration Design

Floor structures are designed for ultimate limit state and serviceability limit state criteria. Ultimate limit state is related to strength and stability. Serviceability limit states are mainly related to vibrations and hence are governed by stiffness, mass, damping and the excitation mechanisms. For slender floor structures such as those constructed in steel, serviceability criteria can govern the design. For the prediction of vibration, several dynamic floor characteristics need to be determined. The design and assessment methods for floor vibrations are related to human induced resonant vibrations, mainly caused by walking under normal conditions.

For a detailed explanation of floor vibration, reference should be made to the Hera Report R4-112 and R4-113.

Durability

STATEMENT: When supplied and installed in accordance with the manufacturer's specifications and design parameters, the SPEEDFLOOR® Steel Joist System can reasonably be expected to meet the performance criteria set out in clause B2, Durability of the New Zealand Building Code for a period of not less than 50 years'.

The durability of a galvanised coating is dependent on the thickness of the zinc coating, the general environment and the level of maintenance carried out over the life of the product. Consideration must be given of these factors when specifying SPEEDFLOOR® to determine the longevity the structural solution. Further clarification of protective coatings and corrosivity zones should be sought from the AS/NZS 2312:2002 Guide to the protection of structural steel against atmospheric corrosion by the use of protective coatings and HERA Report R4 -133:2005.

If any doubt exists on the suitability of SPEEDFLOOR® in a corrosive zone, approval should be sought in writing, as SPEEDFLOOR® accepts no liability for the product other than when used in accordance with the above recommendations.



19 June 2018

Serviceable Life

The rollformed joist is manufactured from steel coated with 275g/sqm of zinc. If the joists are in a clean and dry environment they will require little or no maintenance. If they are exposed, they will require a minimum amount of maintenance to ensure the expected performance is achieved. Guidelines for this maintenance are:

1. Keep surfaces clean and free from continuous contact with moisture, dust and other debris (a 14 MPa waterblast every 2 years will suffice).
2. Periodically inspect the joists for any signs of surface corrosion. Remove any by-products of the corrosion by mechanical means and spot prime the exposed steel substrate with an approved steel primer. Repaint the area using an appropriate paint to manufacturer's recommendations.

Storage and Handling

Bundles of SPEEDFLOOR® Joists should be kept dry during transport. Following transport, bundles should be covered and stored off the ground on dunnage at a slight angle to avoid water or condensation from being trapped between the surfaces.

If bundles become wet, beams should be separated as soon as possible, wiped with a clean cloth and placed apart to allow air circulation.

Avoid sliding beams over rough surfaces or each other.



19 June 2018



Phone: +64 9 303 4825

Email: sales@speedfloor.co.nz

16B Ormiston Rd, East Tamaki, Auckland 2016

www.speedfloor.co.nz